

1. Introduction to Motor Control Centres (MCC)
2. Governing IEC Standards
3. MCC Panel Design Principles
4. Single Line Wiring Diagram
5. Sizing Calculations
 - 5.1 Motor Full Load Current (FLC)
 - 5.2 Cable Sizing
 - 5.3 Contactor & Overload Sizing
 - 5.4 MCCB / MPCB Sizing
 - 5.5 Busbar Sizing
 - 5.6 Short-Circuit Withstand (Icw)
6. Enclosure, IP Rating & Form of Separation
7. Cost Estimation Guide
8. Using the Companion Excel Template

MCC Panel Design Guide

IEC Standards, Wiring Diagram, Cost & Sizing Calculations

A practical reference for engineers specifying, sizing and

costing Motor Control Centre panels to IEC 61439-1/2,

IEC 60947-4-1 and IEC 60364-5-52.

Includes companion Excel sizing & cost template

1. Introduction to Motor Control Centres (MCC)

A Motor Control Centre (MCC) is an assembly of one or more enclosed vertical sections housing combination motor control units, feeder breakers, and associated protection, switching, metering and control devices. MCCs centralise the control and protection of multiple motor loads in a facility - typically found in water treatment plants, oil and gas facilities, manufacturing plants, HVAC systems and process industries.

Each vertical section is generally fed from a common horizontal busbar, with individual feeder compartments (or 'buckets') containing the breaker, contactor and overload relay for each connected motor or load. A well designed MCC balances electrical safety, maintainability, future spare capacity and cost.

2. Governing IEC Standards

Standard	Scope
IEC 61439-1	General rules for low-voltage switchgear and controlgear assemblies
IEC 61439-2	Particular requirements for power switchgear and controlgear assemblies (covers MCCs and PSC assemblies)
IEC 60947-1 / -2	General rules and circuit-breakers for low-voltage switchgear
IEC 60947-4-1	Contactors and motor-starters - electromechanical
IEC 60364-5-52	Electrical installations - selection and erection of wiring systems (cable sizing/derating)
IEC 60529	Degrees of protection provided by enclosures (IP code)
IEC 61641	Guidance for testing under internal arc fault conditions

IEC 61439-2 replaced the older IEC 60439-1 and shifted verification from a purely type-tested model to a system combining design verification (by calculation, comparison or testing) with routine verification of every assembled panel - relevant to how a panel builder demonstrates compliance today.

3. MCC Panel Design Principles

Form of separation

IEC 61439-2 defines Forms 1 to 4 (with sub-variants a/b), describing the degree of separation between busbars and functional units, and between one functional unit and its neighbours. Higher forms improve safety and allow live maintenance of one feeder while others remain energised, at added enclosure cost and footprint.

Rated diversity factor (RDF)

Not every motor runs simultaneously at full load. IEC 61439-2 allows a rated diversity factor to be declared for the whole assembly so the incomer and busbar are not oversized for a coincidence of loads that never occurs.

Segregation and access

Power, control and instrumentation wiring should be segregated in separate trunking to limit electromagnetic interference and simplify fault-finding. Feeder compartments should allow safe access without exposing adjacent live busbars.

Thermal management

Heat generated by breakers, contactors and busbars must be dissipated within the enclosure's rated temperature rise; forced ventilation or air conditioning may be required for high-density panels in hot ambients.

Future spare capacity

Reserving spare feeder ways (commonly 15-25% of installed ways) and sizing the incomer and busbar with margin avoids costly panel replacement when the facility expands.

4. Single Line Wiring Diagram

The diagram below illustrates a typical MCC single line arrangement: incoming supply, incomer breaker, main busbar, and individual feeder ways showing different starting methods (DOL, star-delta, soft starter and VFD).

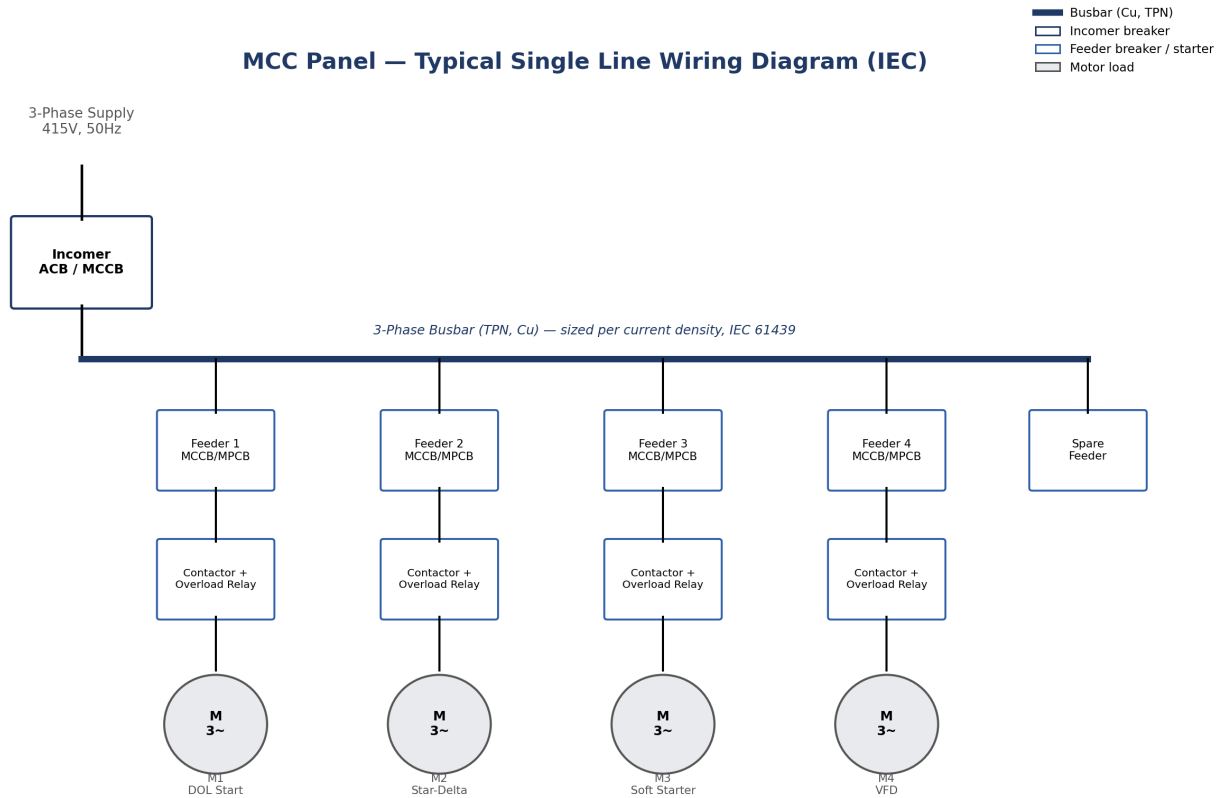

Figure 1 - Typical MCC single line wiring diagram

Each feeder way is protected by its own MCCB or motor protection circuit breaker (MPCB), feeding a contactor and thermal overload relay sized to the motor's full load current. VFD-fed motors are protected upstream by a breaker sized to the drive's rated input current rather than the motor's FLC directly.

5. Sizing Calculations

5.1 Motor Full Load Current (FLC)

For a three-phase motor, full load current is derived from rated power, voltage, efficiency and power factor:

$$\text{FLC (A)} = [P(\text{kW}) \times 1000] / [\text{SQRT}(3) \times V(\text{line-line}) \times \text{Efficiency} \times \text{Power Factor}]$$

Example: a 37 kW, 415V motor with 92% efficiency and 0.86 power factor draws approximately 66.6 A at full load.

5.2 Cable Sizing

Cable sizing per IEC 60364-5-52 starts from the design current (FLC adjusted for service factor) and selects the smallest cross-section whose tabulated ampacity - after applying correction factors for ambient temperature, grouping, and installation method - meets or exceeds that current, while also satisfying voltage-drop and short-circuit thermal withstand checks over the cable's route length.

The companion Excel template includes an indicative ampacity reference table and automatically proposes a cable size for each motor feeder; always re-verify against the full correction-factor tables for the specific installation.

5.3 Contactor & Overload Sizing

Contactors are selected to IEC 60947-4-1 utilisation category AC-3 (starting and switching off standard squirrel-cage motors during running) with a rated operational current at least equal to the motor FLC, generally rounded up to the next standard AC-3 frame size. Thermal overload relays are then set within roughly 105-120% of FLC (for a Class 10 or Class 20 trip characteristic) so the relay trips before motor winding damage occurs on a stall or single-phasing condition, while tolerating normal starting current.

5.4 MCCB / MPCB Sizing

The feeder breaker (MCCB or a dedicated motor protection circuit breaker, MPCB) must carry motor starting current without nuisance tripping while still clearing short circuits fast enough to protect the cable and contactor. A common starting point is 1.25x the motor design current for DOL and star-delta starting, rounded up to the next standard frame size; soft-starter and VFD-fed feeders are instead sized from the starter/drive's rated input current per the manufacturer's datasheet.

5.5 Busbar Sizing

Busbar cross-section is derived from the assembly's design current (after applying the rated diversity factor) divided by an appropriate current density - typically 1.2 to 1.6 A/mm² for enclosed, naturally air-cooled copper busbar - then rounded up to the nearest standard bar size. Busbar supports, phase spacing and enclosure temperature rise must additionally satisfy the assembly's declared IEC 61439-2 temperature-rise verification.

5.6 Short-Circuit Withstand (I_{cw})

Every busbar, breaker and contactor in the assembly must withstand the prospective short-circuit current available at its location for the duration the upstream protection takes to clear the fault. IEC 61439-2 requires this rated short-time withstand current (I_{cw}) or, for lower ratings, the rated peak withstand current, to be verified by calculation, comparison with a tested reference design, or physical short-circuit testing - it is not adequately covered by current rating alone and should be checked by a qualified engineer using the utility or generator's actual fault-level data.

6. Enclosure, IP Rating & Form of Separation

Environment	Typical IP Rating	Notes
Clean indoor plant room	IP31 / IP42	Basic protection from dust and dripping water
Industrial indoor, dusty	IP54	Common default for indoor MCC rooms
Outdoor / washdown areas	IP65	Gasketed doors, cable glands, drip shields
Hazardous area adjacent	IP66 + Ex-rated ancillaries	Confirm zone classification and certified equipment

Forms of separation (IEC 61439-2, Form 1 to Form 4b) trade off cost against the ability to safely isolate and work on one feeder while the rest of the MCC stays live. Form 4b - separating busbars, each functional unit, and each unit's terminals - is common on critical process plant MCCs where individual feeders may need maintenance without a full shutdown.

7. Cost Estimation Guide

Budgetary MCC pricing is usually built bottom-up from a bill of materials, then adjusted for engineering, testing, transport, installation and contingency. Typical cost drivers, in descending order of impact, are:

- Number and rating of feeder ways - more feeders and higher motor kW ratings drive up breaker, contactor and cable costs roughly linearly.
- Form of separation and IP rating - moving from Form 1 to Form 4b, or IP42 to IP65, can add 15-40% to enclosure cost.
- Incomer breaker type - air circuit breakers (ACBs) for high current ratings cost substantially more than moulded-case breakers (MCCBs).
- Control sophistication - PLC/SCADA integration, VFDs, and soft-starters add cost per way compared with basic DOL starters.
- Testing and documentation - a witnessed factory acceptance test (FAT) and full IEC 61439-2 verification documentation add engineering hours.
- Freight and site works - civil works, cable trays, and site commissioning labour vary strongly by project location.

As a rough order-of-magnitude only, a mid-sized industrial MCC with 8-12 feeder ways, Form 3b/4a separation and basic metering commonly falls in the low tens of thousands of USD for the panel itself, before installation, commissioning and site works - always confirm with vendor quotations for the actual project scope.

8. Using the Companion Excel Template

The companion workbook, *MCC_Panel_Design_Calculator.xlsx*, turns the calculations in Section 5 into a working tool with five sheets:

Instructions: Overview, colour-coding key and the engineering disclaimer.

Incomer & Busbar: Enter total connected load, voltage, PF, efficiency and diversity factor to get full load current, design current, a recommended incomer breaker frame, and required busbar cross-section.

Motor Feeder Sizing: A per-motor table: enter nameplate kW, voltage, efficiency, PF and starting method; the sheet calculates FLC, proposes a cable size, contactor rating, overload trip range, and MCCB/MPCB rating.

Cable Ampacity Ref: An indicative IEC 60364-5-52 style ampacity reference table used by the lookup formulas on the Motor Feeder Sizing sheet.

Cost Estimation (BOM): An editable bill of materials with quantities and unit rates, automatically totalling subtotal, contingency and grand total.

All blue-highlighted cells are inputs; black formula cells recalculate automatically. Replace the sample motors and BOM unit rates with your own project data before relying on the outputs.

9. Design Checklist

- Load list finalised with kW, voltage, PF, efficiency and starting method for every motor
- Diversity/demand factor agreed and documented for the assembly
- Incomer and busbar sized with margin for declared spare capacity
- Cable sizes verified against actual installation method and grouping/derating factors
- Contactor AC-3 rating and overload trip class confirmed against motor characteristics
- Feeder MCCB/MPCB coordinated with contactor and cable for both overload and short-circuit protection
- Short-circuit withstand (I_{cw}) verified against the site's actual prospective fault current
- Form of separation and IP rating matched to the installation environment and maintenance philosophy
- Discrimination (selectivity) study completed between incomer and feeder protective devices
- Arc-flash risk assessed and labelled per the applicable local standard
- Factory acceptance test (FAT) and IEC 61439-2 verification documentation planned

10. Engineering Disclaimer

This guide and its companion spreadsheet provide general educational information and preliminary, budgetary sizing only. They are not a substitute for a project-specific engineering design, protection coordination (discrimination) study, arc-flash assessment, or short-circuit withstand verification carried out by a licensed electrical engineer. Standards referenced (IEC 61439, IEC 60947, IEC 60364, IEC 60529, IEC 61641) are cited for general orientation; always consult the current official edition and any applicable local wiring regulations before finalising, manufacturing, energising or operating any MCC panel.